



Design and development of a gripper system for micromanipulation

Demarest Julien

**Supervisor: Dr Bala Amavasai & Jacques Ricard
Training period 2007**

Acknowledgments

Fist of all, I would like to offer my sincere thanks to my supervisor, Doctor Bala Amavasai for all his help, support, advice, patience, and above all time, he has gave me throughout the course of my study.

I would like to acknowledge my French supervisor, Mr. Jacques Ricard, for his advice and pleasant visit during my training period.

I would also like to say special thanks to Doctor Sue Forder for her receptiveness and kindness and for giving me the opportunity to carry out my training abroad.

I would like to say special thanks to John Stanley and Ralph Gay for helping me to design and fabricate the gripper.

To finish, I would like to say very special thanks to Jan Wedekind for his patience and for his interesting demonstrate of the microscope and help for my research.

Abstract

This report presents the design and development of a gripper for micromanipulation. It is included the research to obtain micro motion as piezoelectricity. Moreover the design of the gripper is explained as the experiments which lead to it.

Résumé

Ce rapport présente la création et le développement d'une pince pour des manipulations microscopiques. Il y sera relaté les recherches permettant d'obtenir des déplacements de l'ordre du micromètre à l'aide de la piézo-électricité. De plus l'explication de la création des pinces et des expériences qui ont permis d'y aboutir sera faite.

Keywords

- Piezoelectric actuator
- Gripper
- Design
- Specifications
- Micromanipulation
- Microscope
- Fabrication
- Conception Assisted by Computer

Table of contents

Acknowledgments.....	3
Abstract.....	4
Résumé.....	4
Keywords.....	5
Table of figures.....	8
General Introduction.....	9
1. Training background	11
1.1. Sheffield.....	11
1.2. Sheffield Hallam University.....	11
1.3. Microsystems and Machine Vision Lab.....	13
2. Automated optical microscope system.....	14
3. Piezoelectricity.....	17
3.1. Principle.....	17
3.2. Piezoelectric actions.....	18
3.3. Piezoelectric Voltage.....	19
3.4. Aging.....	22
3.5. High stress.....	22
3.6. Curie point.....	22
3.7. Dynamic Performance.....	22
3.8. Bi-morph actuator.....	23
3.9. Conclusion of theoretical research.....	23
4. Design of the gripper.....	24
4.1. The choice of the product.....	24
4.2. Specifications.....	24
4.2.1 Specifications due to micropositioning stage.....	25
4.2.1.1 Description of a micropositioning stage.....	25
4.2.1.2How to fix the gripper on the micropositioning stage ?.....	25
4.2.2. Specifications due to the microscope.....	26
4.2.3. Specifications due to piezoelectric actuators.....	27
4.2.4. Specifications due to the fabrication.....	28
4.2.4.1. Description of a three-dimensional printer.....	28
4.2.4.2. Specifications due to the 3D printer.....	29
4.2.4.3. Specifications due to the fabrication cost.....	29
4.3. Answers given.....	29
4.3.1. Answers given to the microscope specifications.....	29
4.3.2. Answers given to the piezoelectric actuators specifications.....	30
4.3.3. Answers to fabrication specifications.....	31
4.3.4. Answers given to the positioning stage specifications.....	32
4.4 The different states of conceptions.....	33
5. Gripper assembly.....	34
6. Problems encountered.....	35
Conclusion.....	36
Bibliography.....	37
Appendix 1: Centers for pure research in the University.....	39
Appendix 2: Micron robots.....	40
Appendix 3: Design of microgripper.....	41
Appendix 4: PL140.10.....	42
Appendix X: 3D printers.....	43

Table of figures

Figure 1: The winter garden.....	10
Figure 2: The atrium – the heart of university.....	11
Figure 3: First Surfi-sculpt object.....	13
Figure 4: Second Surfi-sculpt object.....	13
Figure 5: Extended depth oh view for first object.....	14
Figure 6 Extended depth oh view for second object.....	14
Figure 7: 3D-reconstruction of first object.....	14
Figure 8: 3D-reconstruction of second object.....	14
Figure 9: Leica DM LAM Microscope.....	14
Figure 10: Piezoelectricity principle.....	15
Figure 11: Effect of poling.....	16
Figure 12: Piezoelectric voltages from applicated forces.....	17
Figure 13: Bimorph Effect.....	19
Figure 14: Positioning stage.....	21
Figure 15: Microscope focus distance.....	21
Figure 16: Microscope table center distance.....	22
Figure 17: Piezoelectric actuators dimensions.....	23
Figure 18: Dimension 3D-Printer.....	24
Figure 19: Answers to the microscope specifications.....	26
Figure 20: Piezoelectric actuators slots.....	27
Figure 21: Answers to fabrication specifications.....	28
Figure 22: Answers to positioning stage specifications.....	29
Figure 23: Old design.....	29
Figure 24: New design.....	29
Figure 25: Gripper main part.....	30
Figure 26: Accomplished gripper.....	30

General Introduction

The training period represents one of the best opportunities to put into practice our physics and mechanics background learned during our two years course at the IUT. Students must undertake a project with a company or a research team and have to perform a task linked with an area of physics.

One of my personal wish concerning the training period was to increase my level of English and at the same time to develop my reasoning ability. the opportunity to perform my training period in a laboratory at the Sheffield Hallam University provided me with such an opportunity.

The city of Sheffield is one of the biggest of England , and living here during ten weeks give me the possibility to discover the British way of life.

The Sheffield Hallam University is one of the most progressive of the country and provides high quality research tool to its laboratory. Working in contact with high technology supports is very interesting. I will describe the city and the University in the first part of this report to offer a whole idea of the training background.

In a second time I will present the department I was integrated into. My project comes within the context of nano robotics project. The laboratory is called Micro-system and Machine Vision. It regroups different active projects concerning micromanipulation or autonomous mobile robots for example.

As far as my project is concerned, there is a requirement to develop micro gripping devices to support the micro-assembly processes of micro-system technologies which involve the handling and manipulation of various micro-components.

The aim is to create a tool which enables manipulation of sample under an optic microscope called *Leica DM LAM* automates laboratory microscope for quality control, a description of it will be done.

Design and development of a gripper for micromanipulation

The first step was to understand the piezoelectric materials mechanism. A part of the report concerns the piezoelectric theoretical aspect. Then a thought about the way to use piezoelectricity with the gripper I have to design will be described. It is included a precise description of the bimorph effect which enables the bending of a material.

Description of the specifications which lead to the gripper will take a part of this report as the way to power supply the piezoelectric materials.

My project is to design the gripper, I have to realise it with accuracy. The main objective is to find a way of work for the future project concerning the gripper and add alternative trail.

1. Training background

1.1. Sheffield



Sheffield is a city and metropolitan borough in the South Yorkshire of England. The population of the city is estimated at 520,700 people (2005), and it is the third largest English cities outside London. Sheffield was founded in the early 12th century by the Lord of the manor, William de Lovetot, and is so named because of its origins in a field on the River Sheaf that runs through the town.

The city has grown from industrial roots to encompass a wide economic base. It has become world famous for its production of steel. In recent years the city has attempted to reinvent itself as a sporting and technology city. Sheffield is sixth best location for business in United Kingdom.

In spite of its industrial side, Sheffield wants to develop the tourism and it is redeveloping. The city hosts many attractions and parks including the Weston Park Museum, *The Winter Gardens*, The Millennium Galleries, The Peace Gardens, and Sheffield Botanical Gardens ...

Sheffield has two universities and more than 55,000 students, This town is a very vibrant and friendly learning city.

1.2. Sheffield Hallam University

Sheffield Hallam University (SHU) located in the city of Sheffield is based on three main campuses, one in the city center and two in southwest Sheffield.

With more than 28,000 students, over 3,000 staff and 650 courses, the university is the country's sixth largest. The British press place Sheffield Hallam among the leading modern universities. The university's research is also highly-rated (an official assessment in 2001 placed SHU joint top among modern universities).

The e-learning system at SHU is one of the most extensive and advanced at any university in the country. The University has vibrant and diverse student population with over 3,000 international students who come from over 80 different countries around the world. Indeed, 12 per cent of students come from overseas. After a distinguished history as one of Britain's top schools of art and design for more than a century, it became one of the colleges that merged with the city's College of Technology in 1969 to form Sheffield Polytechnic (one of the first polytechnics in United Kingdom).

In 1976, the Polytechnic was renamed Sheffield City Polytechnic when it absorbed the city's two teacher training colleges, one of which was itself founded back in 1902. Along with all other British polytechnics, Sheffield City Polytechnic became a university with the right to award its own degrees in 1992, and thus became Sheffield Hallam University.

Sheffield Hallam University is divided into four faculties:



Figure 2: The Atrium – The heart of the University

- Faculty of Arts, Computing, Engineering and Science (ACES): Computing & Management Sciences, Engineering and Science & Mathematics.
- Faculty of Development and Society: Built Environment, Architecture, Surveying, Construction, Urban Regeneration, Cultural Studies, Education, Environment and Social Science & Law.
- Faculty of Health and Wellbeing: Health & Social Care, Science & Mathematics, Sport & Leisure Management.
- Faculty of Organisation and Management: Business & Finance, Environment & Development, Sport & Leisure Management.

To push its research agenda, there are approximately twenty centers for pure research (*Appendix 1*) which had been formed. All of them have had outstanding success in government research exercises.

1.3. Microsystems and Machine Vision Lab

~~During my training period I stayed at the I was integrated into~~ Microsystems and Machine Vision Lab ~~to perform my training period~~. It ~~is was~~ part of Materials Engineering Research Institute in the Sheffield Hallam University. This internationally recognised center covers a broad range of materials and engineering research.

The main research activities involved the design, development and implementation of machine vision techniques targeted at a variety of real-time and non real-time applications which included micro-robotic systems, biological applications, micromanipulation, microscope imaging, Scanning Electron Microscopy (SEM) and Transmission Electron Microscopy (TEM) applications and non-destructive testing of Micro-Electro-Mechanical System (MEMS) devices.

Design and development of a gripper for micromanipulation

I worked particularly in parallel of Micron project. Its goal was to develop a multi-robot manipulation system with the ability of handling micrometer-sized objects. This system was based on a cluster of small mobile robots which were autonomous thanks with on-board electronics equipping each of them. These wireless robots (*Appendix 2*) could be equipped with various tools such as syringe-chips or the gripper I had to design. They could also cooperate to accomplish a range of task associated with assembly and processing from the nano to micro-range.

Members of the staff were senior lecturers as my supervisor, senior research fellows, and PhD or ERASMUS students. The laboratory was divided in three rooms, two for informatics and office automation tasks, and the other one with access control which contained microscopes and micromanipulation devices.

2. Automated optical microscope system

The tools I had to design would be integrated in the functioning of the *Leica DM LAM* automated optical microscope for feedback control.

Leica Microsystems Automation was unique in this form. The combination of motorized microscope, external control satellite and PC allowed perfect remote operation of the microscope in a variety of ways.

It could be used for 3D surface metrology that allowed for the non-destructive measurement of surface profiles. Using our experimental settings we observed:

- Vertical resolution of 30 μm and better (depending on aperture-size, magnification, projection-pattern and the surface properties of the object).
- Lateral resolution of 26 μm and better (depends).
- Captured area about 0.5 mm^2 (can be improved by using a motorized X-Y table and stitching software).

As a demonstration, below are some typical microscope images (showing a surface, which has been shaped using a laser beam).

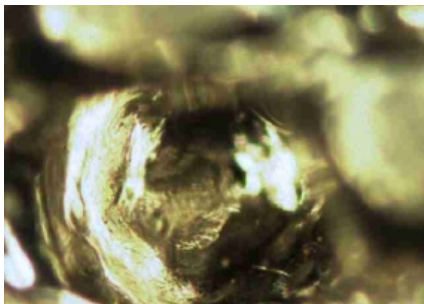

Figure 3: First Surfi-sculpt object

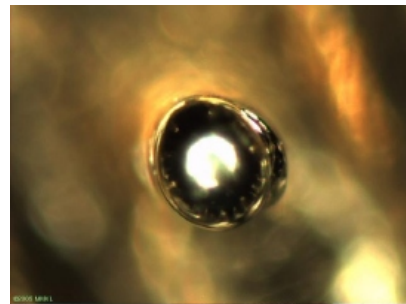

Figure 4: Second Surfi-sculpt object

Using a focus-stack one could compute images with extended depth of focus:



view for
view for
first object

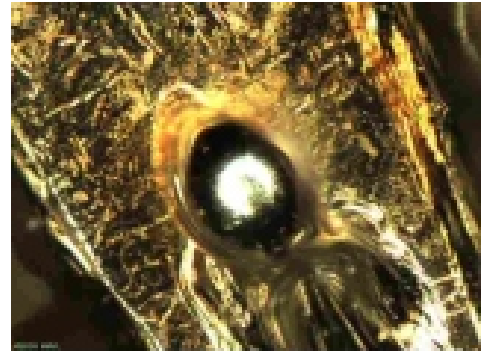

Figure 5:
Extended depth of
Figure 6: Extended depth of

second object

If the surface could be illuminated properly, algorithms existed to perform a 3D-reconstruction of the surface.



reconstruction of first
Figure 8: 3D-
reconstruction of second
object
object



Figure 7:
3D-

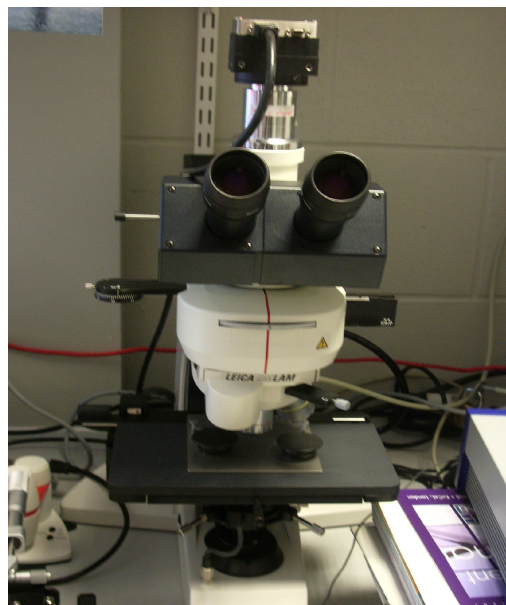

Figure 9: Leica DM LAM Microscope

3. Piezoelectricity

Piezoelectricity, as its name indicates, used electricity. Motion could be produced when an electrical field was generated. A vast amount of information was available about the way to create the gripper using material. That was why this system has been chosen to achieve the task.

3.1. Principle

Piezoelectricity ~~is~~ ~~was~~ property exhibited by certain classes of crystalline materials. When mechanical pressure ~~is~~ ~~was~~ applied to one of these materials, the crystalline structure produces ~~ed~~ a voltage proportional to the pressure (*Figure 10*). Conversely, when an electrical field ~~is~~ ~~was~~ applied to one of these materials, the crystalline structure changes ~~ed~~ shape producing dimensional changes in the material. Piezoelectricity was discovered by Pierre and Jacques Curie in the 1880's.

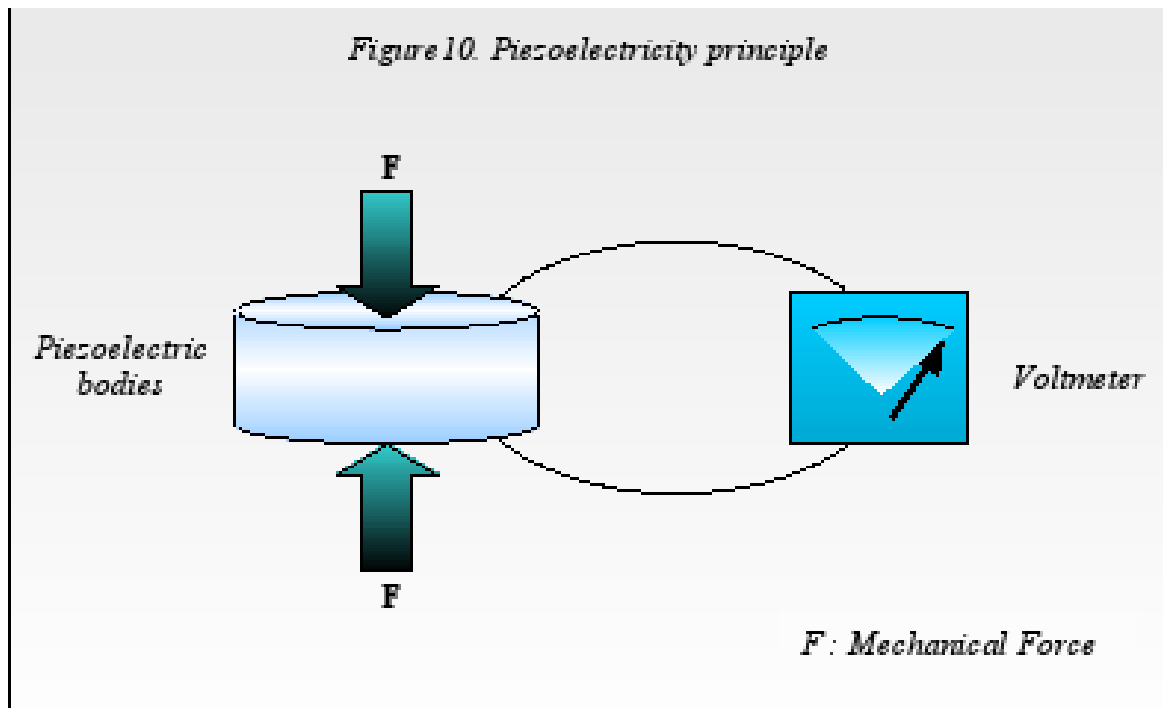

Piezoelectric bodies provided a coupling between electrical and mechanical forces and hence as transducers between electrical and mechanical energy. In principle, they could complete with all other electromechanical transducers, including electromagnetic motors and generators. In practice, piezoelectric transducers ~~are~~ ~~were~~ limited to devices involving only very small mechanical displacements and small amounts of electric charge per cycle.

Effective use of piezoelectric devices depended on matching the electrical and mechanical impedance of the energy source and the driven load. The limited charge density and strain amplitude of piezoelectric made them unattractive for low frequency applications (such as 60 Hz) and essentially inoperative for static forces and fields. They became increasingly useful with an increase in frequency because electric current was proportional to charge times frequency.

3.2. Piezoelectric actions

The poling process permanently changes the dimensions of ceramic element. The dimension between the poling electrode (X) increases, and the dimensions parallel to the electrode (Y) decrease. These effects were shown greatly exaggerated in *Figure 11*. The dimension between the poling electrode (a) is called the poling axis.

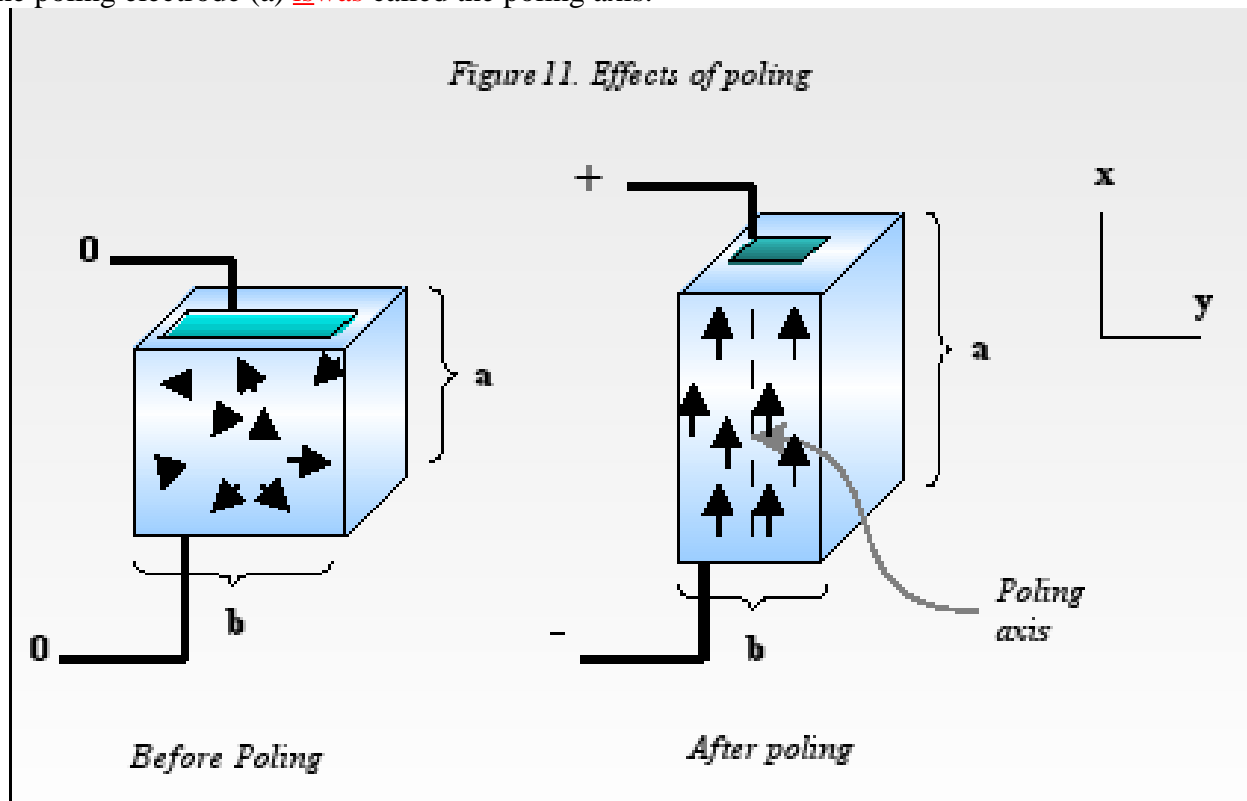

As soon as the poling process was complete, a lower voltage than the poling voltage changed the dimension of a ceramic element for as long as the voltage was applied. A voltage with the same polarity as the poling voltage caused additional expansion along the poling axis (X) and contraction perpendicular to the poling axis (Y). A voltage with the opposite polarity had the opposite effect. In both cases, the ceramic element returned to its poled dimensions when the voltage was removed from electrodes.

A ceramic material ~~iswas~~ composed of many randomly oriented crystals or grains. With the dipoles randomly oriented, the material ~~iswas~~ isotropic and ~~does~~ not exhibit the piezoelectric effect. By applying electrodes and a strong electric field, the dipoles ~~would~~ tend to align themselves parallel to the field, so that the material ~~haswould have~~ permanent polarization.

3.3. Piezoelectric Voltage.

After the poling process ~~was~~ complete, compressive and tensile forces applied to the ceramic element generated a voltage. Refer to *Figure 12*. A voltage with the same polarity as the poling voltage result~~ed~~ from a compressive force (a) applied parallel to the polling axis, or from a tensile (c) applied parallel to the poling axis, or from a compressive force (d) applied perpendicular to the poling axis.

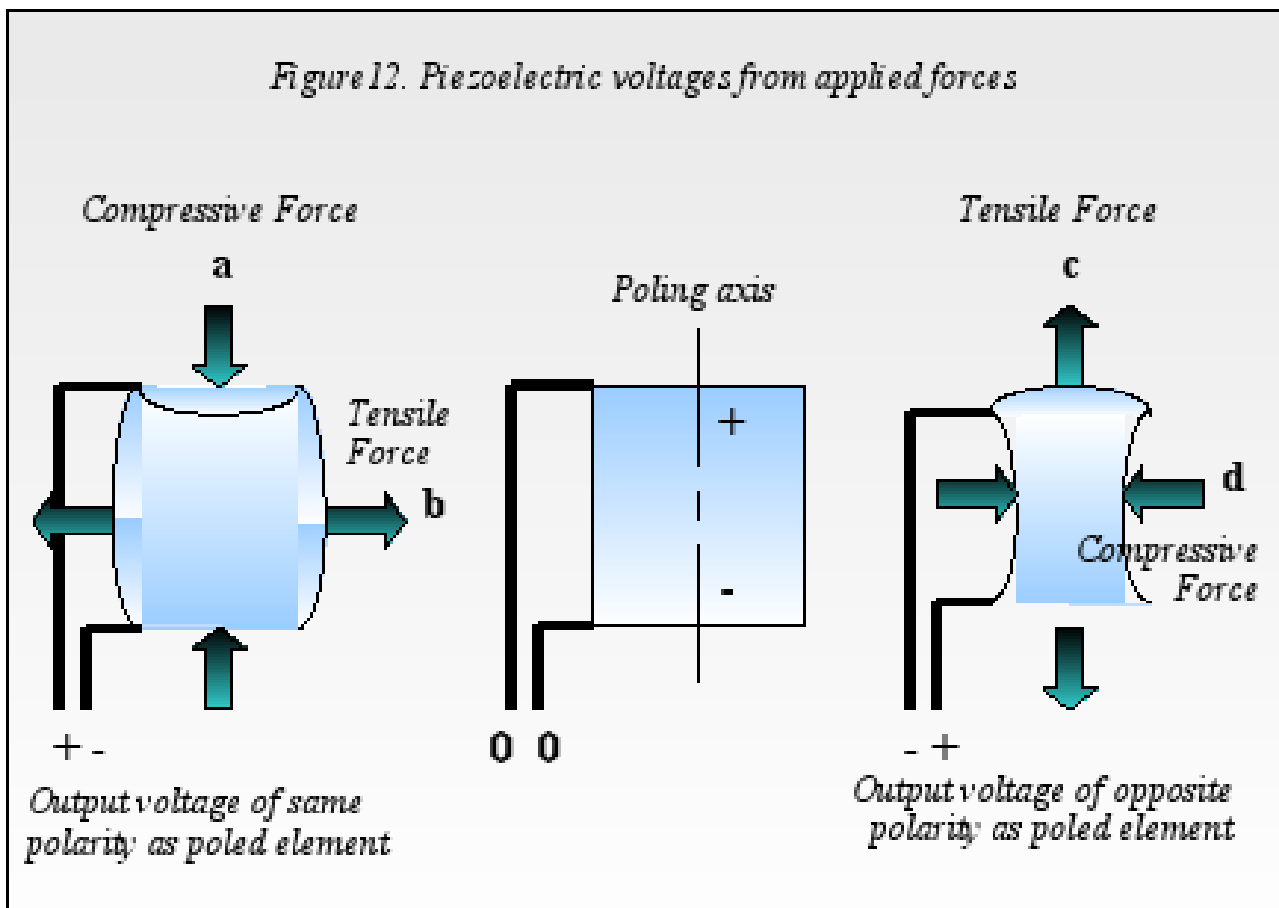

3.4. Aging

Most of the properties of piezoelectric ceramics changed with time. The changes tended to be logarithmic with time after poling. Because of aging, exact values of various properties such as dielectric constant, coupling, and piezoelectric constants might only be specified for standard time after poling. The longer the time period after poling iswas, the more stable the material becoames.

3.5. High stress

Most of the properties of piezoelectric ceramics varyied with the level of applied mechanical stress or voltage. Data iswas usually presented for piezoelectric ceramics at fairly low levels. Operating at high levels accelerated the aging process.

3.6. Curie point

The Curie point iswas the absolute maximum exposure temperature for any piezoelectric ceramic. Each ceramic composition hasd its own Curie point. When the ceramic element iswas heated above the Curie point, all piezoelectric properties arewere lost. At elevated temperatures, the aging process accelerated, electrical losses increase, efficiency decreases, and the maximum safe stress level iswas reduced. For example, the Curie point of Barium Titanate 300 iswas 115°C and for Lead zirconite Titanate 300°C (this two materials arewere piezoelectric ceramics).

3.7. Dynamic Performance

Dynamic performances related to the behaviour of a material when it iswas subjected to alternating fields or stresses at frequencies close to the mechanical resonance of a component. To obtain optimum performance from a piezoelectric device, the circuit to which it iswas connected must haved certain characteristics which arewere dictated by the design of the device. In discussing this subject, it iswas convenient to divide piezoelectric devices into two categories:

- Non-resonant devices were so named because they arewere designed to operate below resonance or over a relative large frequency range.
- A resonant device either operated at its mechanical resonance or over a band of less than one octave around this resonance.

3.8. Bi-morph actuator

A mechanism that put something into automatic action *is was* called actuator. In engineering, actuator *are were* devices which transformed input signal into motion.

A piezoelectric bi-morph actuator *is was* created by flattening layers of piezoelectric.

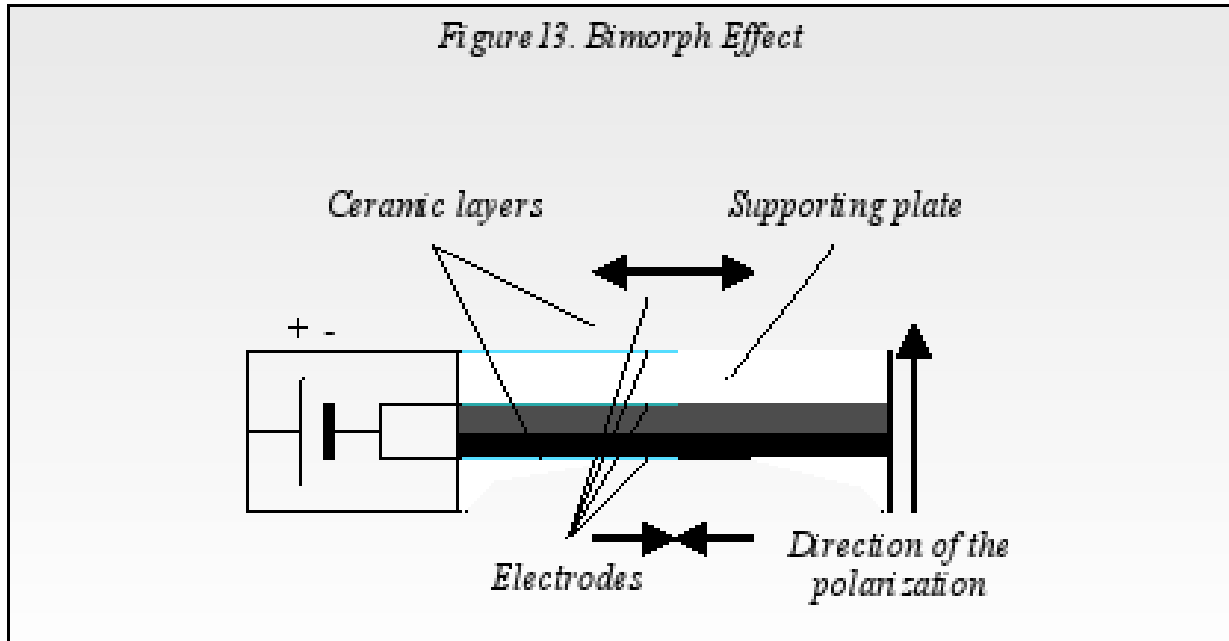

3.9. Conclusion of theoretical research

Piezoelectricity offered a very *high* accuracy and *was* simple *to design with*. Moreover piezoelectric bi-morph actuators seemed to be perfect to obtain the bending required for the work of the gripper. In addition to that we had examples of grippers that used piezoelectric material to function (*Appendix 3*). This document gave an idea concerning the design of the gripper.

4. Design of the gripper

The design of the gripper was the most important part of my project. It had been carried out in collaboration with the researcher and the workshop.

4.1. The choice of the product

There ~~are~~was a lot of different bi-morph actuators ~~available on the market in different catalogue~~. So some characteristics of the gripper had been determined. Obviously the ~~range of motion offered by size of~~ the actuator had ~~s~~ to correspond with the size of the sample manipulated.

The choice of the products had been discussed with the researcher in charge of the manipulation of the microscope. ~~The field of view of the microscope imposes a constraint on the maximum size of the object~~~~The lens focus of the microscope helped us to determine the ideal bender actuator~~. We concluded that a piezo actuator with 1.00 mm nominal displacement would be the most useful for the gripper system.

Amongst the bi-morph actuators which presented the required displacement, the one easiest to use had been chosen. That means a bender which could be integrated in micro gripper and in an electrical circuit. ~~After a product survey the Researches led to PI products, the~~ PL140.10 Piezo Bender Actuators ~~by PI were chosen~~ (*Appendix 4*).

In addition of the multilayer Bender, it had been decided to use an amplifier designed to be used with it. the LVPZT Amplifier was specifically designed to drive Multilayer Bi-morph Actuators such as the PL140.10. It was equipped with a special circuit that could provide one fixed voltage and a variable voltage in the range of 0 to 60 V. It could be operated in two ways: manual control with DC offset potentiometer or with an external control thanks to an analog signal in the range of 0 to 10 V applied to the BNC input.

The addition of this amplifier and the multilayer bender actuators reduced uncertainly of manipulations and measurements.

4.2. Specifications

The gripper design had to correspond with a lot of specifications. Indeed the gripper would be used under a microscope and assembled on a micropositioning stage, so specifications were given by their dimensions. Moreover, other specifications were given by the dimensions of the piezoelectric actuators and some other were due to fabrication specifications.

4.2.1 Specifications due to micropositioning stage

The gripper would be associated with a micropositioning stage. Indeed this tool would permit to the gripper to move with a micron accuracy.

4.2.1.1 Description of a micropositioning stage

The micropositioning stage was a table which could move in all directions thanks to different micrometric screws. Fix the gripper on a such tools was the best way to move it with accuracy.

4.2.1.2 How to fix the gripper on the micropositioning stage ?

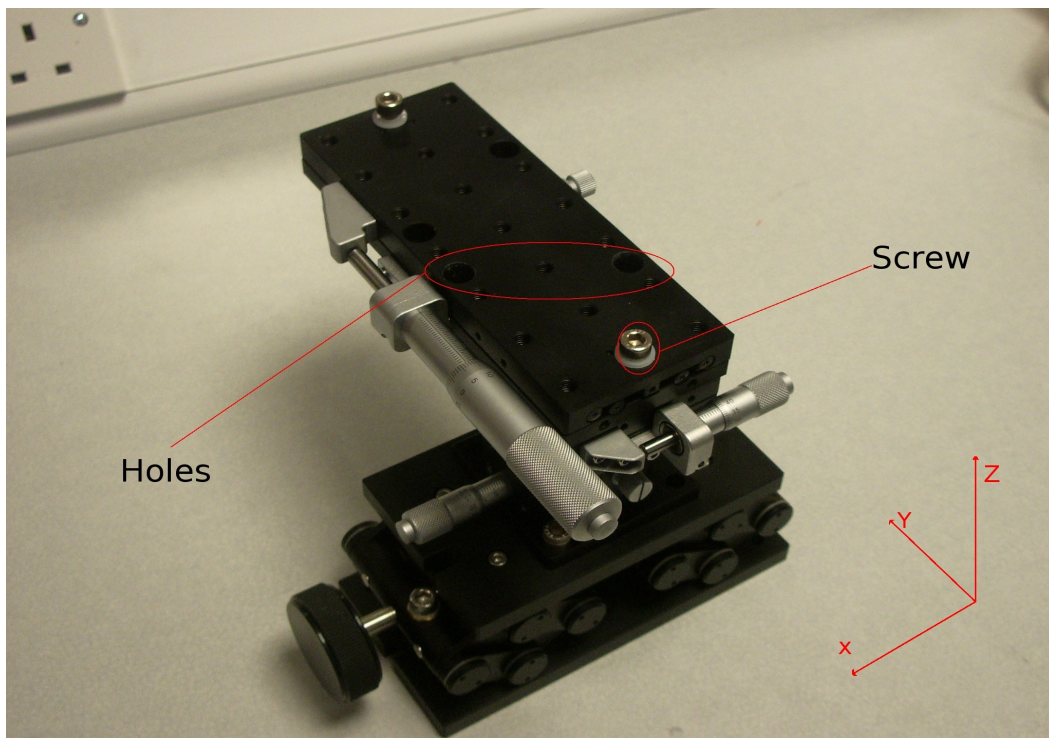

Figure 14: Micropositioning stage

The two holes of the positioning stage would be used in order to block the gripper in X and Y directions. The screw would fix the gripper in Z direction.

4.2.2. Specifications due to the microscope

The gripper were designed to work with the *Leica DM LAM* microscope. The focus distance of this instrument were fixed and a contact between the gripper and the microscope lens was forbidden. That was why the gripper design had to respect the focus distance.

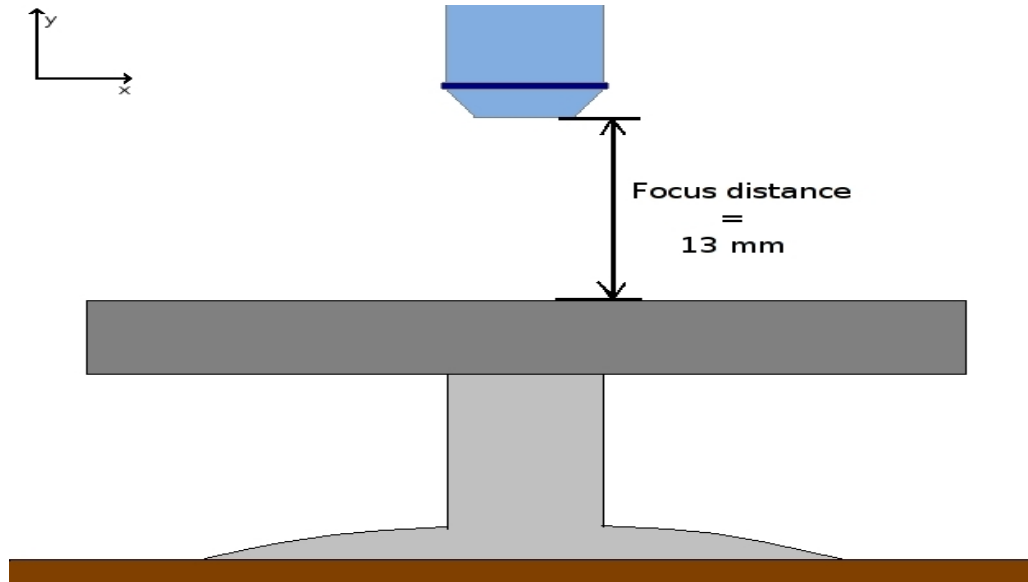

Figure 15: Microscope focus distance

Moreover, the gripper would be able to grip a sample which was located at the center of the microscope table. Indeed the microscope table can move following the z axis direction by half of its size. So if the gripper was able to grip a sample at the center of the microscope table it would be able to grip a sample everywhere on the table by moving it.

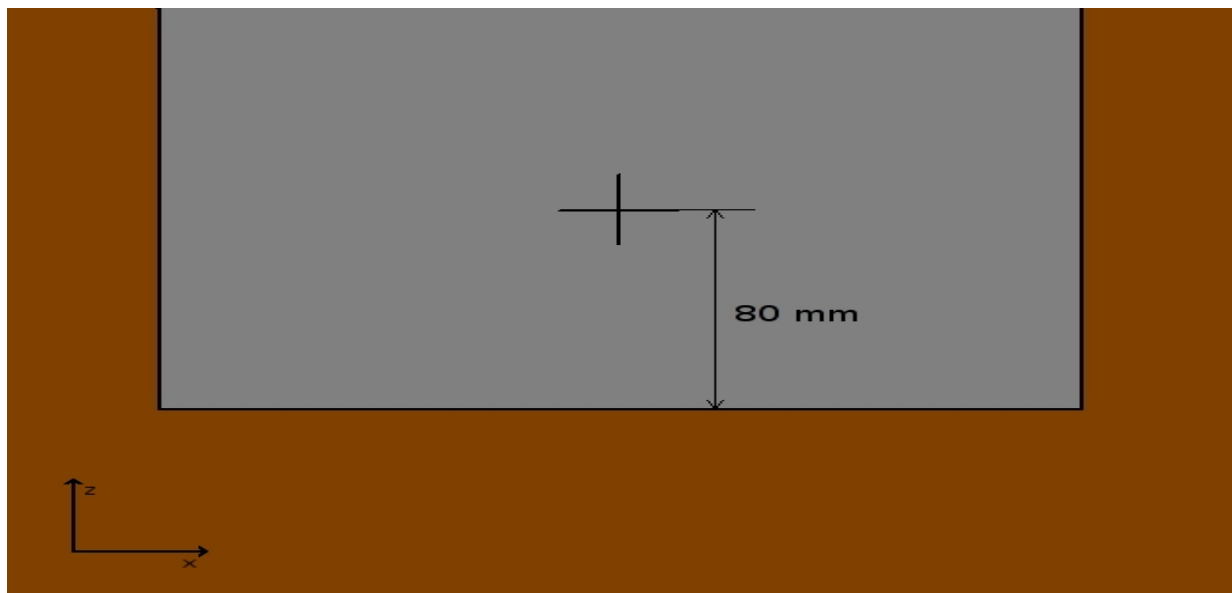

Figure 16: Microscope table center distance

4.2.3. Specifications due to piezoelectric actuators

Piezoelectric actuators could not be manipulated without care. Indeed, They ~~are~~ driven by electricity so using conductive material for the main part of the gripper was forbidden. Isolating

Design and development of a gripper for micromanipulation

material must be used in order to not perturb the piezoelectric actuators behavior.

Moreover, the dimensions of the piezoelectric actuators needed to be respected.

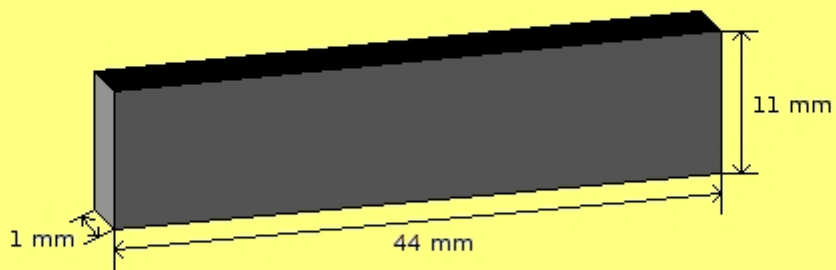

Figure 17: Piezoelectric actuators dimensions

4.2.4. Specifications due to the fabrication

The gripper body was realised with a three-dimensional printer. This printer imposed some specifications.

4.2.4.1. Description of a three-dimensional printer

Three-dimensional printing **iswas** a method of converting a virtual 3Dmodel into a physical object. 3D printing **iswas** a category of rapid prototyping technology. 3D printers **arewere** generally faster, more affordable and easier to use than other rapid prototyping technologies.

In Hallam university, the three-dimensional printer used Fuse Deposition Modeller (FDM), a technology also used in traditional rapid prototyping use**se** a nozzle to deposit molten polymer onto a support structure, layer by layer. This technology was marketed commercially by Stratasys with their Dimension models. (*Appendix 5*)



Figure 18:
Dimension 3D-
Printer

4.2.4.2. Specifications due to the 3D printer

Every plastic parts had to be thicker than 0.25 mm. Indeed 0.25 mm was the plastic layer size laid down by the printer. In the same way, every holes diameter had to be bigger than 0.5 mm.

4.2.4.3. Specifications due to the fabrication cost

Plastic quantity used had to be as skimpy as possible because the plastic used in the three dimensional printer was expensive and the aim of an engineer is to create a low cost design.

4.3. Answers given

In order to design a gripper which corresponded to all these specifications, I used a software called Solidwork. It ~~is~~was a software for conception assisted by computer. This software ~~w~~asis very famous and a lot of companies use~~d~~ it all over the world.

4.3.1. Answers given to the microscope specifications

In the gripper main part design was integrated a sort of arm which permitted to reach the center of the microscope. In order to not touch the lens and to be able to catch micro-sample, something thin and which offered a good compromise between the fact to be thin and a good hardness had to be used. Tungsten wire had been chosen because of its ~~propertiesgoods~~particularities.

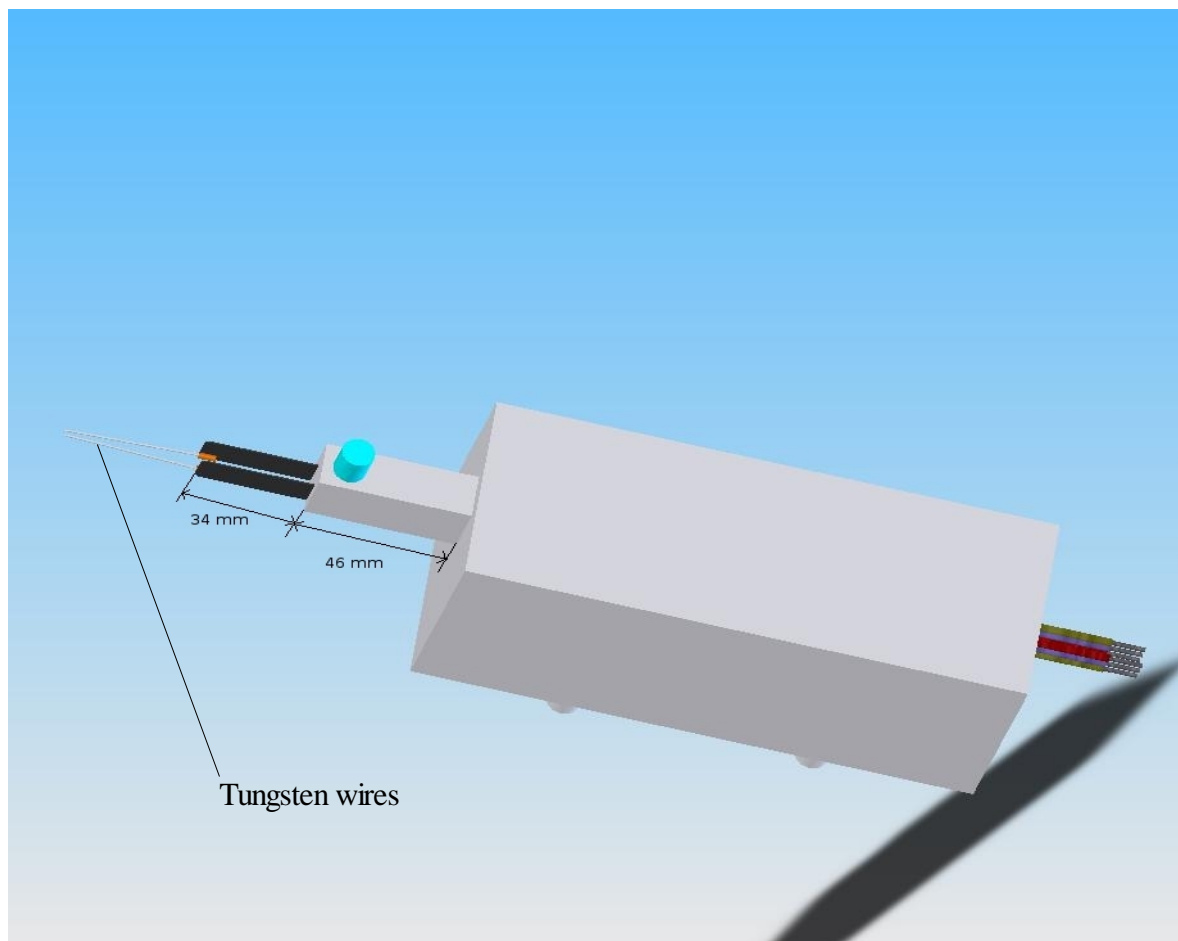

Figure 19: Answers to the microscope specifications

4.3.2. Answers given to the piezoelectric actuators specifications

To respect piezoelectric actuators specifications, ABS plastic ~~was had been~~ chosen to be the gripper main part material. Indeed, ABS plastic is ~~a~~ hard, light and cheap isolating material which permitted to obtain a solid gripper easy to manipulate.

Moreover, two parallels slots ~~were had been drilled bored~~ in the gripper main part in order to fix in the piezoelectric actuators.

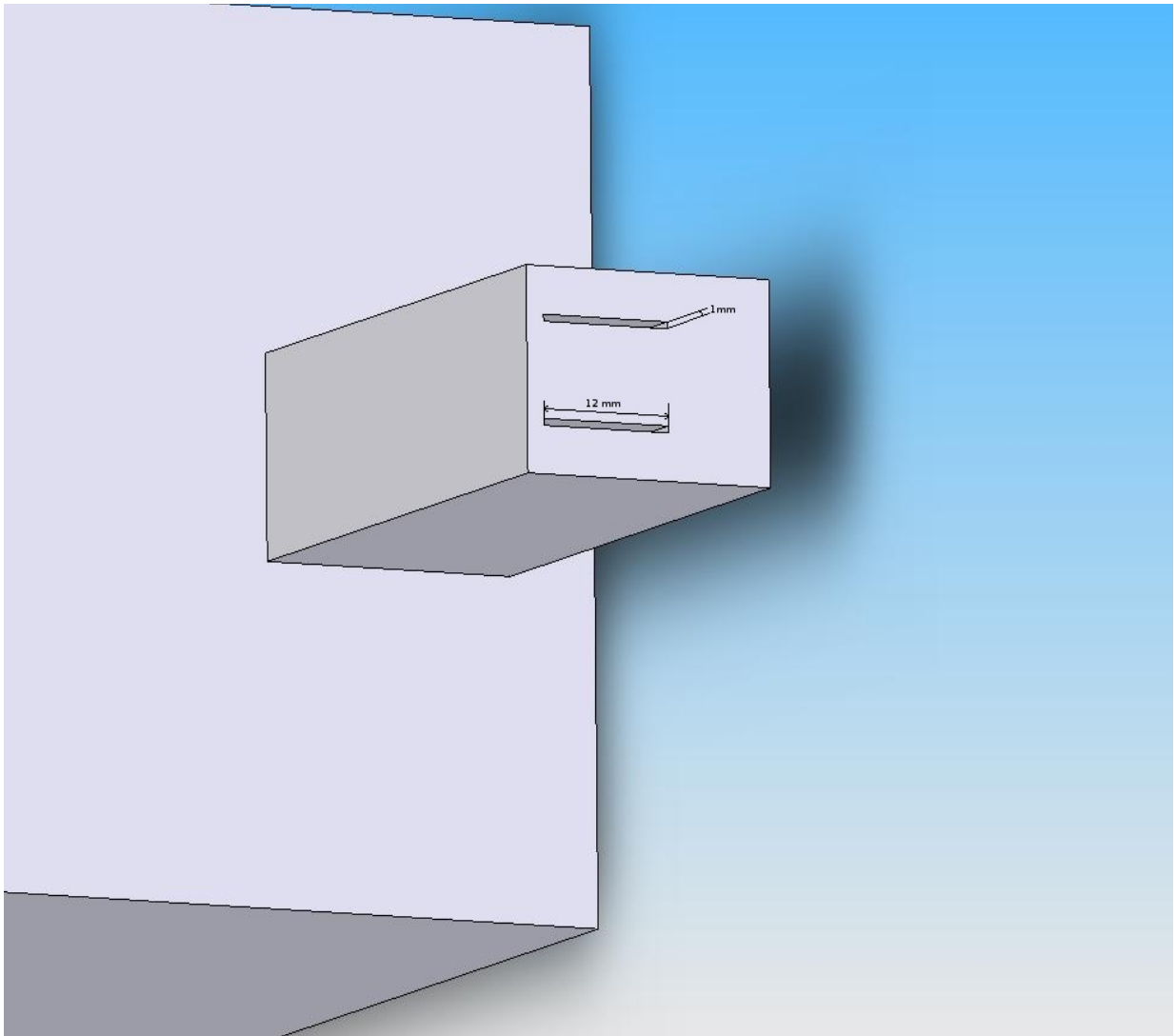

Figure 20: Piezoelectric actuators slots

4.3.3. Answers to fabrication specifications

The gripper main part ~~length-was~~ had been divided ~~in~~by two in order to reduce the fabrication costs. Moreover, always in order to reduce costs, the gripper main part ~~was made hollow~~ had been dug in ~~the intention of to~~ decreasing the material quantity.

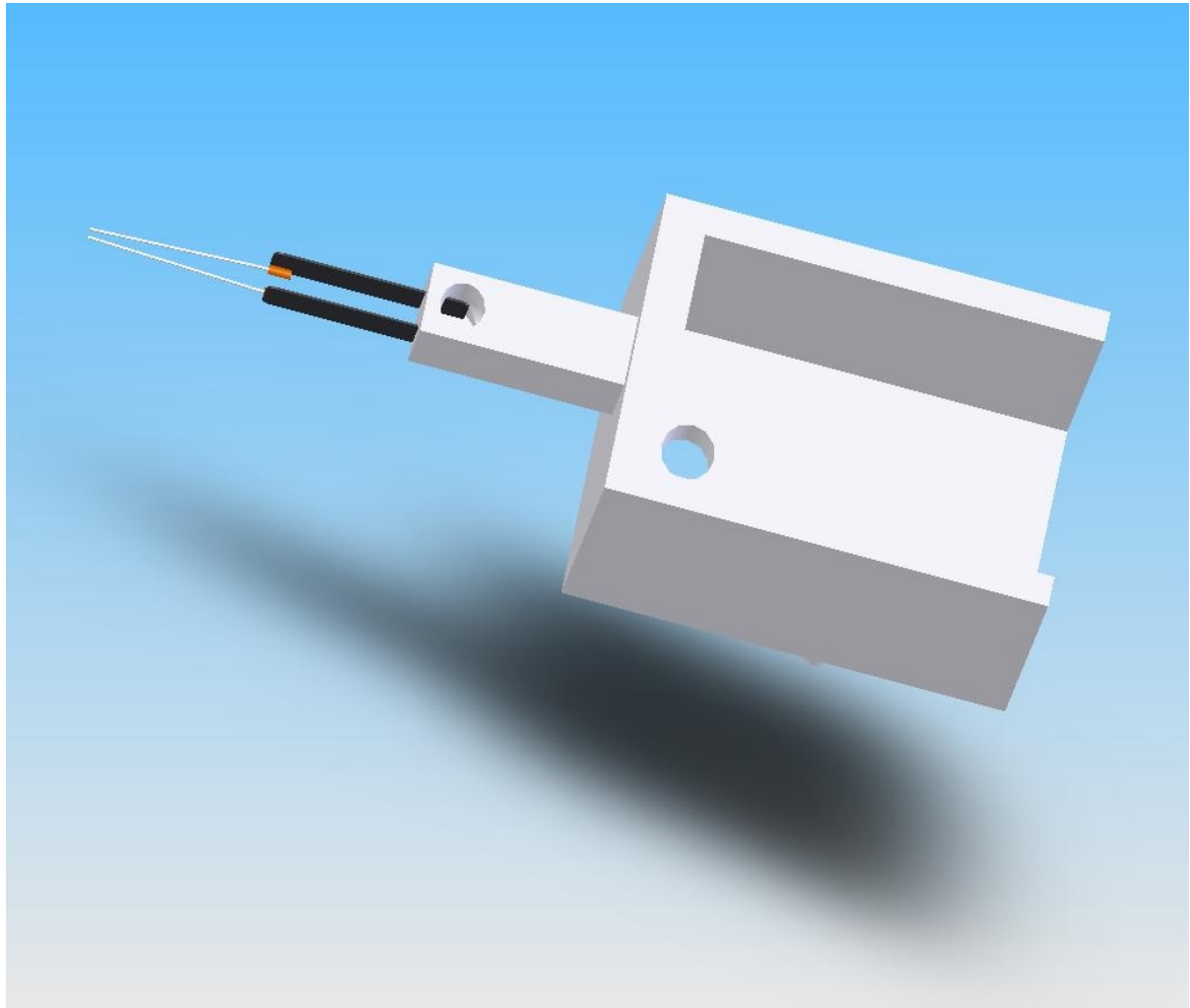

Figure 21: Answers to fabrications specifications

4.3.4. Answers given to the positioning stage specifications

Two plots which had to fill the positioning stage holes were added to the gripper main part. A hole for the positioning stage screw ~~was drilled~~~~had been bored~~.

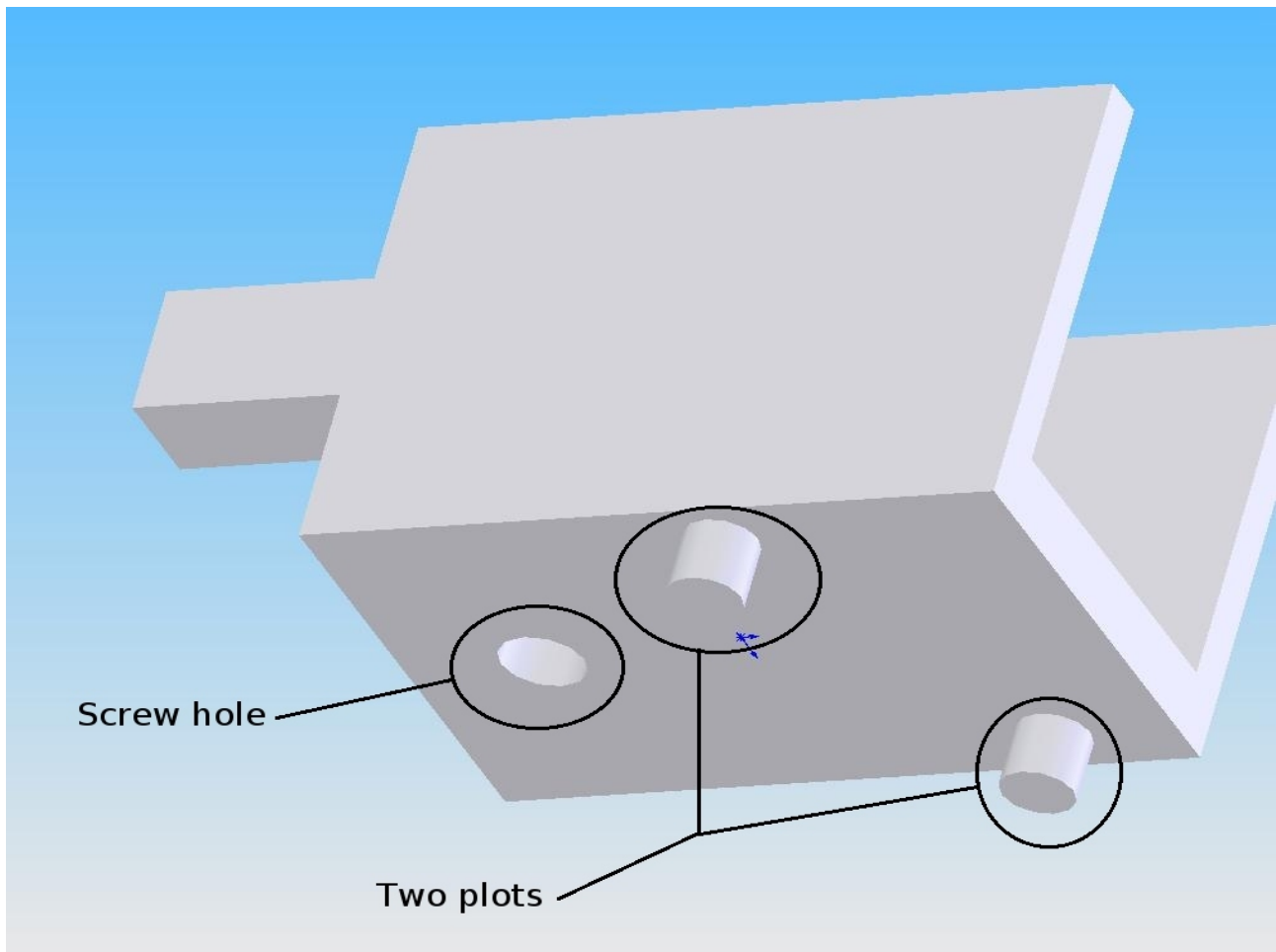

Figure 22: Answers to positioning stage specifications

4.4 The different states of conceptions

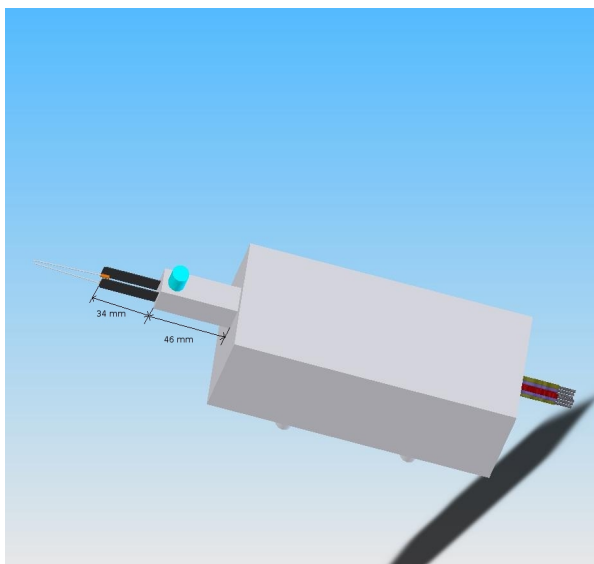

Figure 23: Old design

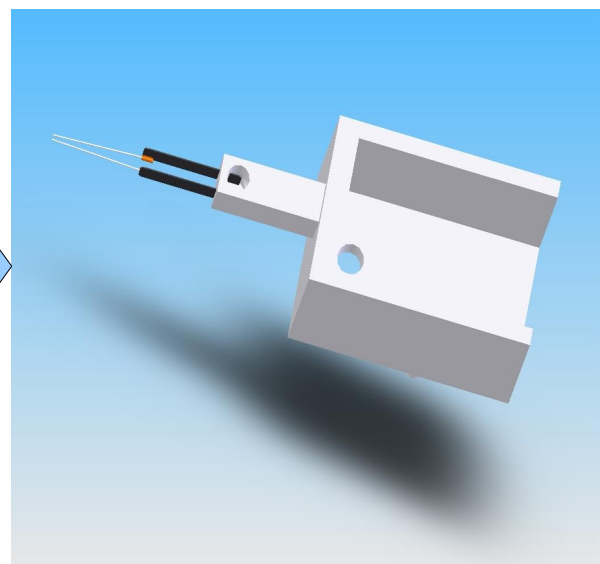

Figure 24: New design

5. Gripper assembly

After its fabrication, the gripper main part had to be filed. Indeed the 3D printer ~~caused~~ some imperfections in ~~the~~ piezoelectric actuator slots.

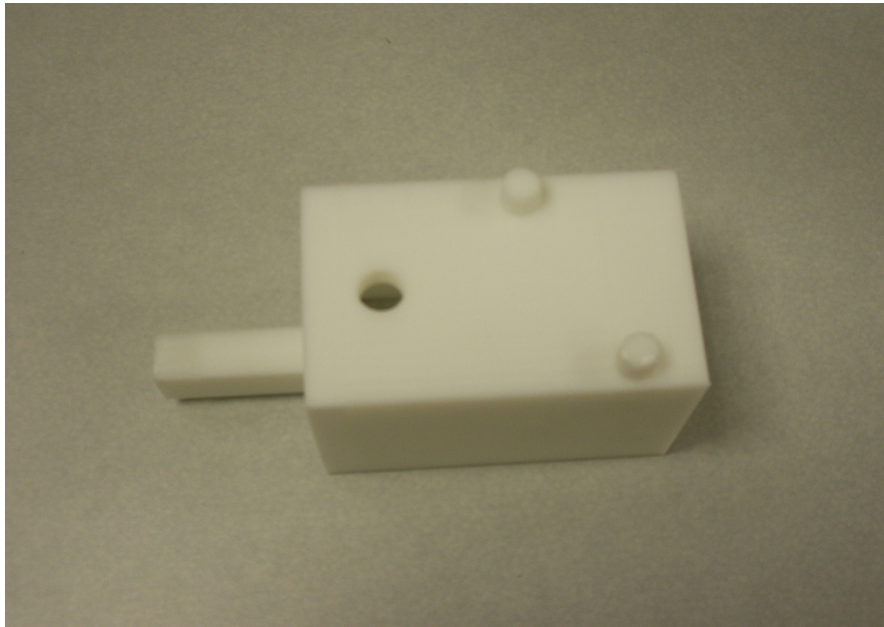

Figure 25:
Gripper main
part

~~Finally~~~~After~~, the piezoelectric actuators ~~were~~~~had~~~~just~~~~to~~~~be~~ inserted in their slots and the gripper ~~waste~~~~be~~ fixed on the positioning stage.

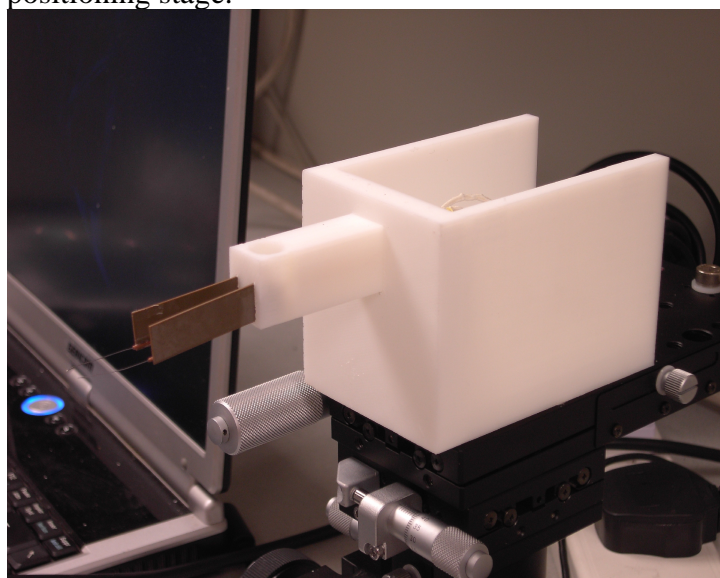

Figure 26:
Accomplished
gripper

6. Problems encountered

Obviously for a foreign student the languages was the first problem. At the beginning, it was hard to communicate, in the way to understand and to be understood. Moreover my laboratory was composed of researchers coming from all over the world and Erasmus Students. Each person was obviously speaking English with the specific accent of the region where they were coming from.

Moreover, the subject was not very well explained. There was no specifications and I did not understand why they asked me to do a gripper. If I should have passed more time to establish the specifications at the beginning, I should have lost less time and I should have be able to do a more evolved gripper (driven by computer).

Furthermore, I lost four working days because I had an entrance exam for an engineering school in France (Centrale Nantes).

Conclusion

This training period was very interesting from my personal side. Indeed it combined technical work with research development. I managed my project in collaboration with staff members, students, and technicians, which gave me a foundation for the future professional work. It improves my English level thanks to the contact of different persons from different departments.

Moreover, I learned a lot about mechanical conception. Indeed, pure mechanical conception was not learned during my course. However all lessons about conception assisted by computer helped me when I had to realise the gripper main part.

To finish, this placement highlights the quality of the IUT training. Indeed the physical background received during the last two years enable me a better approach of the stages of my training which have concerned electronics, materials, and mechanics area.

Bibliography

Jaffe Bernard and Cook William. *Piezoelectric ceramics*. London and New-York: Academic Press

Holland Richard. *Design of resonant piezoelectric devices*. Research monograph the MIT Press

J. van Randerat, R.E Settingington. *Piezoelectric ceramics*. Mullard Limited

Booklet about *Piezoelectric Ceramics Data book for Designers*. Morgan Matroc Limited

[Ying-Chien Tsai, Sio Hou Lei, Hendra Sudin: Design and analysis of planar compliant microgripper based on kinematic approach](#)

Appendices

Appendix 1: Centers for pure research in the University

- Materials and Engineering Research Institute – MERI
- Biomedical Research Center – BMRC
- Center for Education Research – CER
- Center for Sport and Exercise Science – CSES
- Center for Health and Social Care Research – CHSR
- Center for Professional and Organisational Development – CPOD
- Center for Sustainable Consumption – CSC
- Culture, Communication and Computing Research Institute – C₃I

University spin-off companies formed

- Sheaf Solution – automotive and aerospace organisation
- Material Analysis & Research Service (MARS) Center for Industrial Collaboration – expertise in materials analysis and solutions
- Hallam Biotech – biotechnologie analysis and synthesis
- Bodycote – materials coating
- Design Futures – design providers

Appendix 2: Micron robots

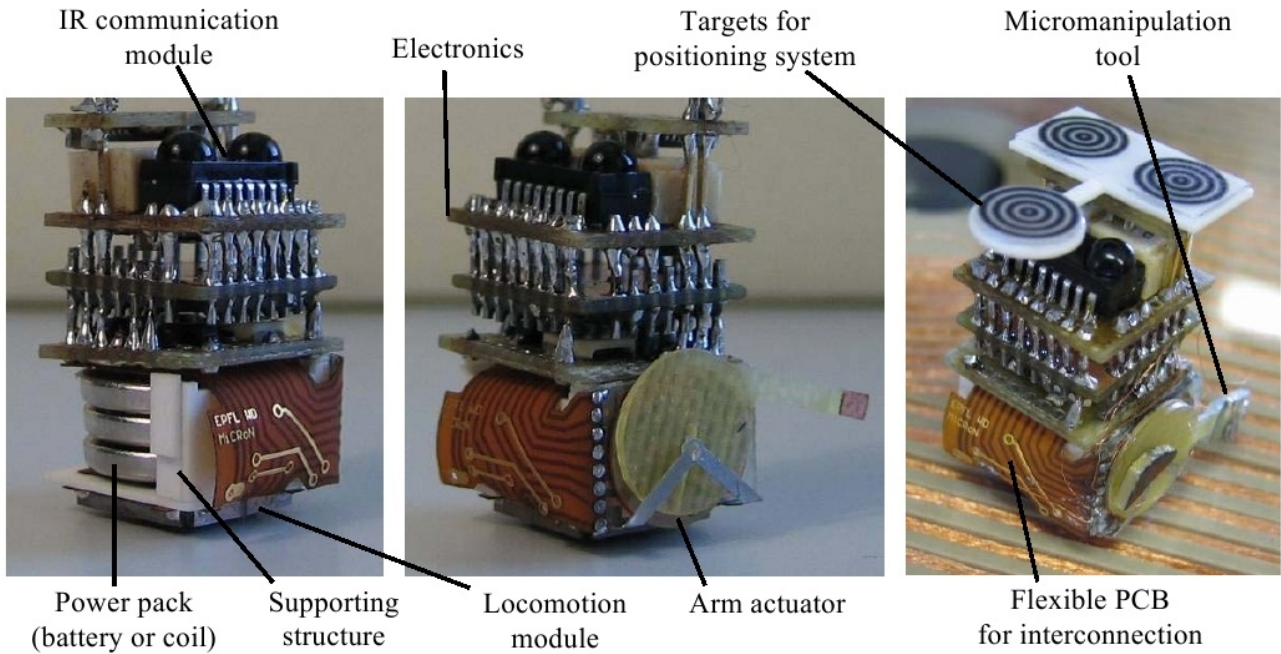

Appendix 3: Design of microgripper

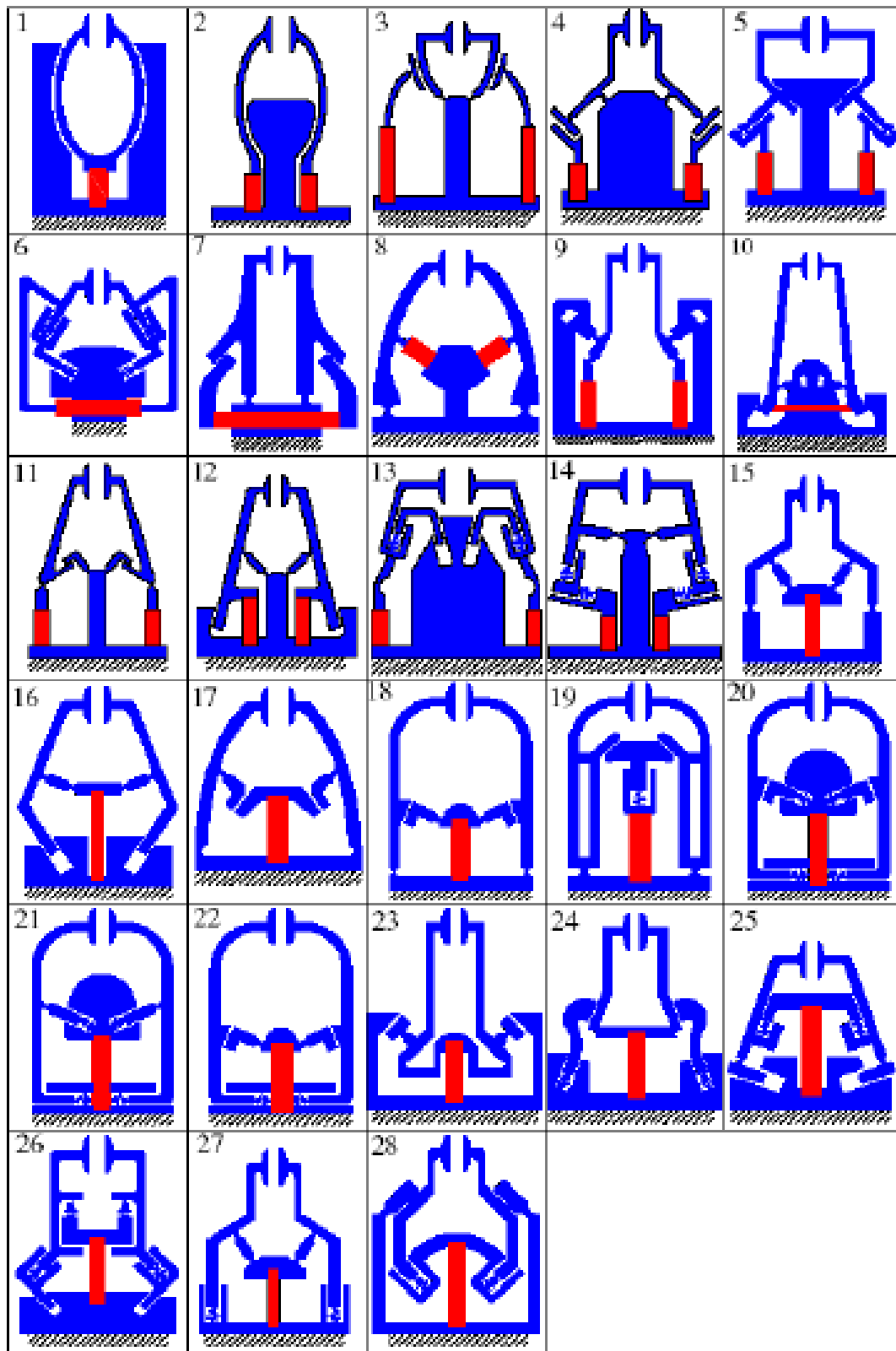

Appendix 4: PL140.10

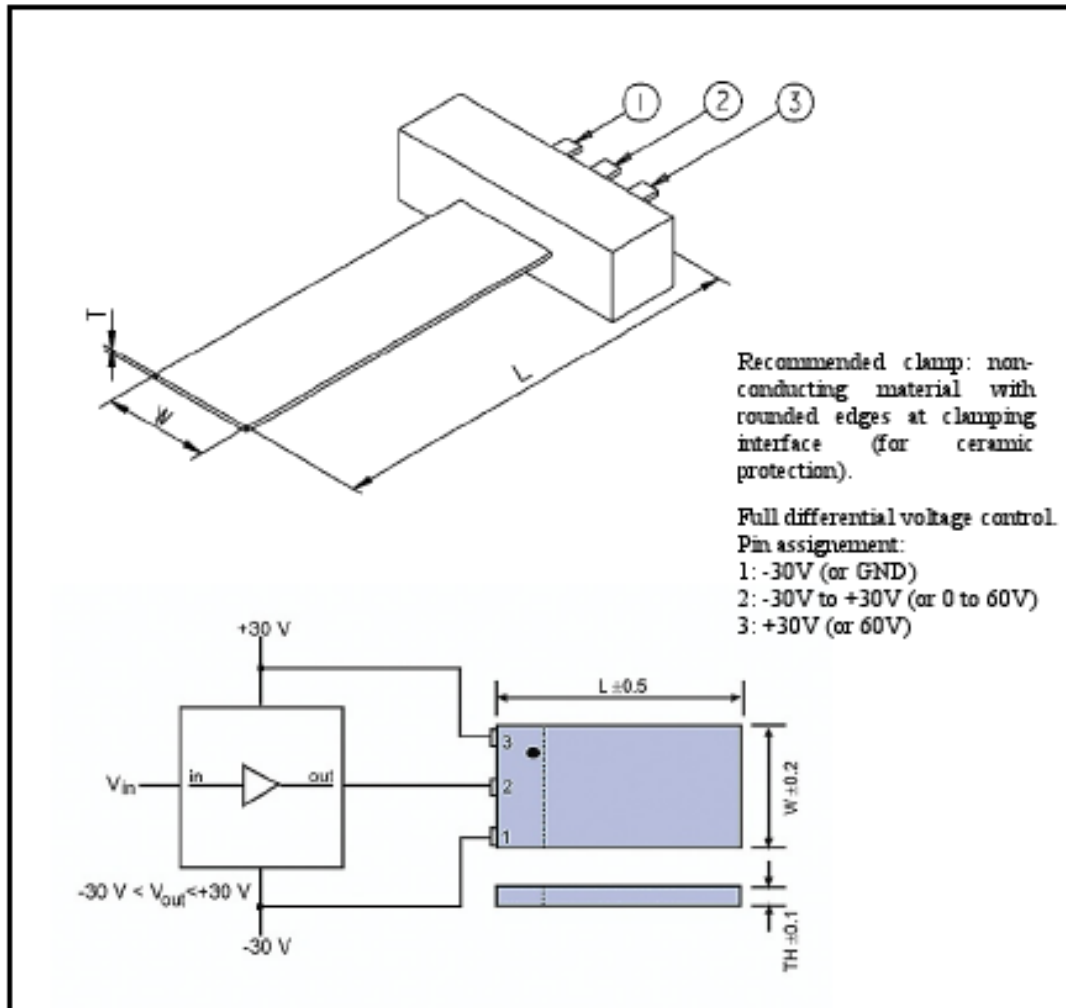

Order number	Operating voltage (V)	Nominal displacement (μm) 20%	Free length (mm)	Dimension $L \times W \times T$ (mm)	Blocking force (N)	Electric capacitance (μF) 20%	Resonant frequency (Hz)
PL140.10	0 - 60	1000	40	45.0*11.0*0.60	0.5	2*4.0	160

Appendix X: 3D printers

Dimension 3D Printers: Essential design tools with distinct advantages.

Nothing communicates design ideas faster than a three-dimensional part or model. With a Dimension 3D Printer, you can bring CAD files and design ideas to life – right from your desktop. Test form, fit and function – and as many design iterations as you like – with functional ABS parts. For added hands-free convenience, consider the Dimension SST with a water soluble support removal system. Starting at €22.900,* Dimension 3D printers represent a major price breakthrough – with leading 3D printing technology.

Simply connect a Dimension 3D printer to your network. Load Catalyst software. Insert the self-loading material cartridges and follow the display panel prompts. That's it. 3D printing with Dimension or Dimension SST is as easy as clicking print. See why a Dimension 3D Printer is the fastest selling office-friendly machine of its kind – and start shortening your design and development cycle.

Automatic Operation:

Catalyst software automatically imports STL files, orients the part, slices the file, generates support structures (if necessary), and creates a precise deposition path to build your ABS model. Multiple models can be packed within the build envelope to maximize efficiency. Catalyst provides queue management capabilities, build time, material status and system status information. Dimension 3D Printers run unattended and provide system and build status information via e-mail, pager, or the Internet.

Network Connectivity:

TCP/IP 100/10 base T

Workstation Compatibility:

Windows NT/Windows 2000/Windows XP

Build Size:

Maximum size 203 x 203 x 305 mm

Materials:

ABS plastic in standard white, blue, yellow, black, red or green colors. Custom colors available.

Support Structures and Removal:

Catalyst software automatically creates any needed support structures to complete the part. Two support removal processes are available. With Dimension, a Break Away Support System allows for easy support removal – simply break away the supports. Dimension SST offers a soluble support removal process for hands-free model completion.

Material Cartridges:

One autoloader cartridge with 922 cu. cm. (56.3 cu. in.) ABS material.
One autoloader cartridge with 922 cu. cm. (56.3 cu. in.) support material.

Layer Thickness:

.245 mm (.010 in.) or .33 mm (.013 in.) of precisely deposited ABS and support material.

Size and Power Requirements:

Size: 686 x 914 x 1041 mm

Weight: 136 kg (300 lbs.)

Power Requirements: 110-120 VAC, 60 Hz, minimum 15A dedicated circuit or 220-240 VAC, 50/60 Hz, minimum 7A dedicated circuit.

Regulatory Compliance: CE

Special facility requirements: None

Stratasys Inc.

14950 Martin Drive

Eden Prairie, MN 55344-2020 U.S.A.

+1 866.721.9244 US Toll Free

info@dimensionprinting.com

www.dimensionprinting.com



* Manufacturers' worldwide list price. Additional options, shipping, applicable taxes/duties not included. © 2004 Stratasys Inc. All rights reserved. Stratasys is a registered trademark. Dimension and Catalyst are trademarks of Stratasys Inc., registered in the U.S.A. and other countries. Windows NT, Windows 2000 and Windows XP are trademarks of their respective owner. Stratasys assumes no responsibility with regard to the selection, performance or use of these products. Product specifications are subject to change without notice. Printed in the U.S.A. DIMS7CC 02/04

Powered by leading Stratasys technology.

dimension